

**Passive Probe**  
无源探极  
**UT-P08A 350MHz**

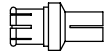

BNC adapte/BNC转接器

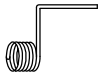

Ground Spring / 接地弹簧



IC Tip / IC针套

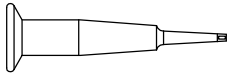

Sprung Hook / 探钩

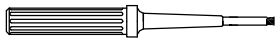

Adjustment Tool / 调试棒



Marker Ring / 色环

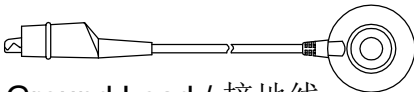

Ground Lead / 接地线

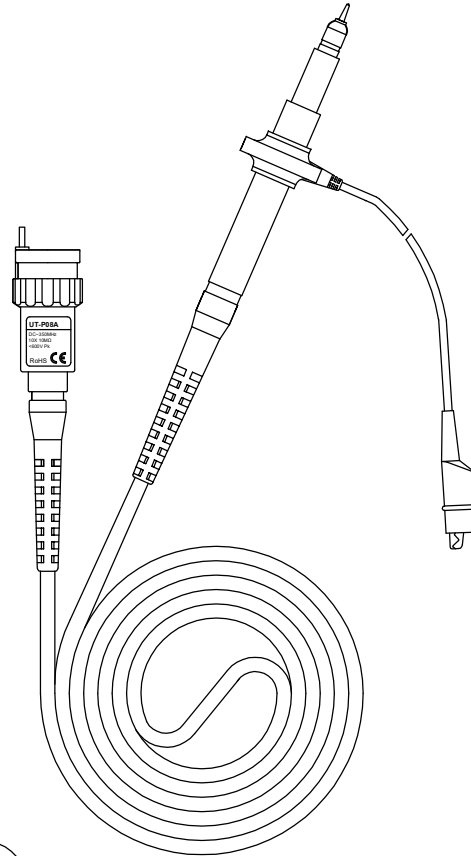

Made in China



## 性能与指标

UT-P08A探极的下列参数要求与其连接的示波器必须具有 1MΩ的输入阻抗。使用的测试设备至少有20分钟的预热时间，并在不超过表中描述的极限环境中使用。

项目	UT-P08A
衰减	10X
输入电阻	10MΩ
输入电容	6.5pF-14.5pF
系统带宽	DC~350MHz
补偿范围	10pF-40pF
最大工作电压	≤600V pk
安全	Conformed IEC-61010 CAT II 300V AC
净重	<55g
线长	120cm±1.5cm
使用温度	-10°C - +50°C
湿度	<85% (相对湿度)

## 维护

### 低频探极补偿

使用探极进行测试前，首先请检查本品的低频补偿，将其调至与使用的示波器匹配。一般的示波器在其前面板上都有一个校准信号输出端，将探极的探针接到此信号输出端，示波器显示1KHz测试信号。如图所示，用调试棒调节探极BNC端的调节孔内的器件，使波形上下平整。

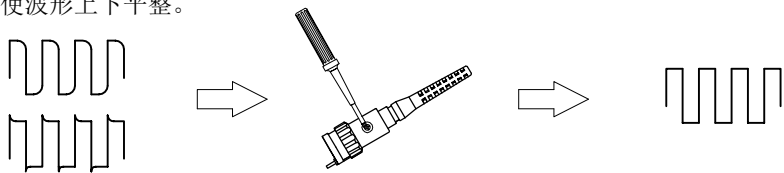

### 电压-频率特性图 (VDC+Peak AC)

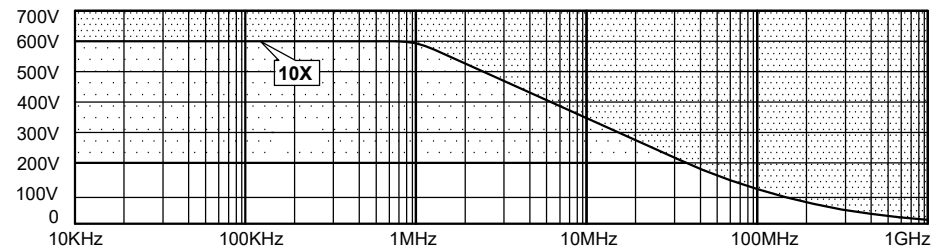

## Specifications

These characteristics apply to a UT-P08A probe installed on a specified oscilloscope. When used with another instrument, the oscilloscope must have an input impedance of 1 MΩ. The instrument must have a warm-up period of at least 20 minutes and be in an environment that does not exceed the limits.

Item	UT-P08A
Attenuation	10X
Input Resistance	10MΩ
Input Capacitance	6.5pF-14.5pF
System Bandwidth	DC~350MHz
Compensation Range	10pF-40pF
Maximum Working Input Voltage	≤600V pk
Safety	Conformed IEC-61010 CAT II 300V AC
Net Weight	<55g
Length	120cm±1.5cm
Temperature	-10°C - +50°C
Humidity	≤85% (Relative Humidity)

## Maintenance

### Compensation Adjustment

Before taking any measurements using a probe, first check the compensation of the probe and adjust it to match the channel inputs. Most oscilloscopes have a square wave reference signal available at a terminal on the front panel used to compensate the probe. Connect the probe to the signal source to display a 1KHz test signal on your oscilloscope.

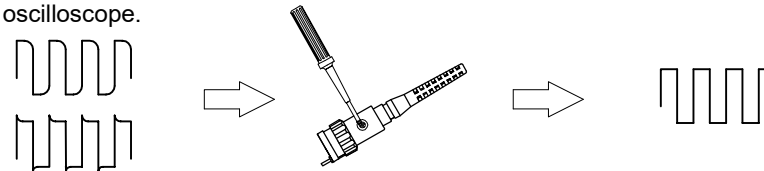

### Maximum Working Voltage Derating Curve (VDC+Peak AC)

